

INSTALLATION AND OPERATING INSTRUCTIONS

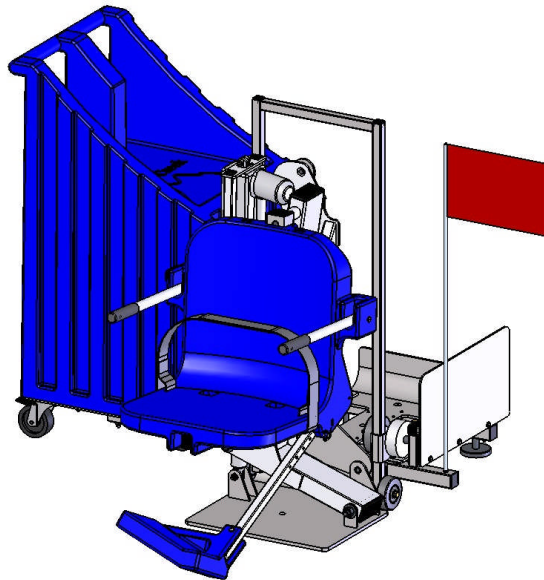

PATRIOT-AT™ PORTABLE LIFT

PART NUMBER: F-12PPL-HD-AT2

U.S. PATENT NUMBERS: [7,249,386 B2] [5,790,995] [D507,769 S]

450 LB. [204 kg] MAXIMUM CAPACITY (PRO POOL LIFT)

MANDATORY – LEAVE THIS MANUAL WITH LIFT OWNER



9889 GARRYMORE LANE
MISSOULA, MT 59808
1-888-687-3552
FAX: 406-549-2602

Inspected And Verified To Meet
Applicable Sections of ADA
Guidelines Section 1009.2 By

wyle
laboratories

A Registered ISO 9001
Laboratory



WARNING

IMPORTANT SAFETY INSTRUCTIONS

- 1. READ AND FOLLOW ALL INSTRUCTIONS. LIFT SAFETY CAN ONLY BE ENSURED IF THE LIFT IS INSTALLED AND OPERATED PROPERLY – AS PER INSTRUCTIONS.**
- 2. WARNING- TO REDUCE RISK OF INJURY, DO NOT PERMIT CHILDREN TO USE THIS PRODUCT UNLESS THEY ARE CLOSELY SUPERVISED AT ALL TIMES.**
- 3. WARNING- DO NOT PERMIT CHILDREN TO PLAY ON THIS PRODUCT.**
- 4. WARNING- NEVER APPLY DIRECT WATER PRESSURE TO ELECTRONIC COMPONENTS.**
- 5. WARNING – DO NOT OPERATE THIS LIFT IF THE DECK-TO-WATER DISTANCE IS OVER 12”.**
- 6. WARNING – DO NOT OPERATE THIS LIFT UNDER LOAD IN A DRY POOL (NO WATER).**
- 7. WARNING – DO NOT OPERATE THIS LIFT WITHOUT THE 10 WEIGHT-PLATES INSTALLED.**
- 8. WARNING – FOR SAFETY REASONS YOU SHOULD NEVER SWIM ALONE!**
- 9. SAVE A COPY OF THESE INSTRUCTIONS.**

PATRIOT-AT™ PORTABLE LIFT

TABLE OF CONTENTS

<u>PAGE</u>	<u>DESCRIPTION</u>
3	ADA INSTALLATION GUIDELINES
4	PATRIOT-AT™ PORTABLE PACKING LIST
5	PATRIOT-AT™ PORTABLE ASSEMBLY INSTRUCTIONS
6	FIXING-ANCHOR INSTALLATION INSTRUCTIONS
7	INSTALLING THE FIXING BOLT
8-9	TRANSPORTING & USING THE PATRIOT-AT™ PORTABLE
10	24V BATTERY OP & INSTALL INSTRUCTIONS
11	BATTERY MAINTENANCE
12	PRO POOL-AT™ LIFT OPERATING INSTRUCTIONS
13	CARE OF YOUR LIFT
14-17	TROUBLESHOOTING GUIDE
18	PATRIOT-AT™ INTEGRATED POOL LIFT: PARTS LIST
19	SEAT ASSEMBLY: PARTS LIST
20	PATRIOT-AT™ PORTABLE CART: PARTS LIST
21	WARRANTY

INSTALLATION: ADA GUIDELINES

ADA REQUIREMENTS:

The PATRIOT-AT™ portable lift is designed and manufactured to be 100% ADA compliant. But for the installed lift to be 100% compliant the installation must meet the requirement for CLEAR DECK SPACE as shown in the diagram to the left. To be compliant, install the lift at 16 inches [406mm] minimum from the pool edge to the centerline of the seat, and make sure the deck has the required CLEAR DECK SPACE as shown.

NOTE: As per ADA requirements the slope of the deck from the pool edge to the centerline of the seat and within the clear deck space must be no greater than 1:48.

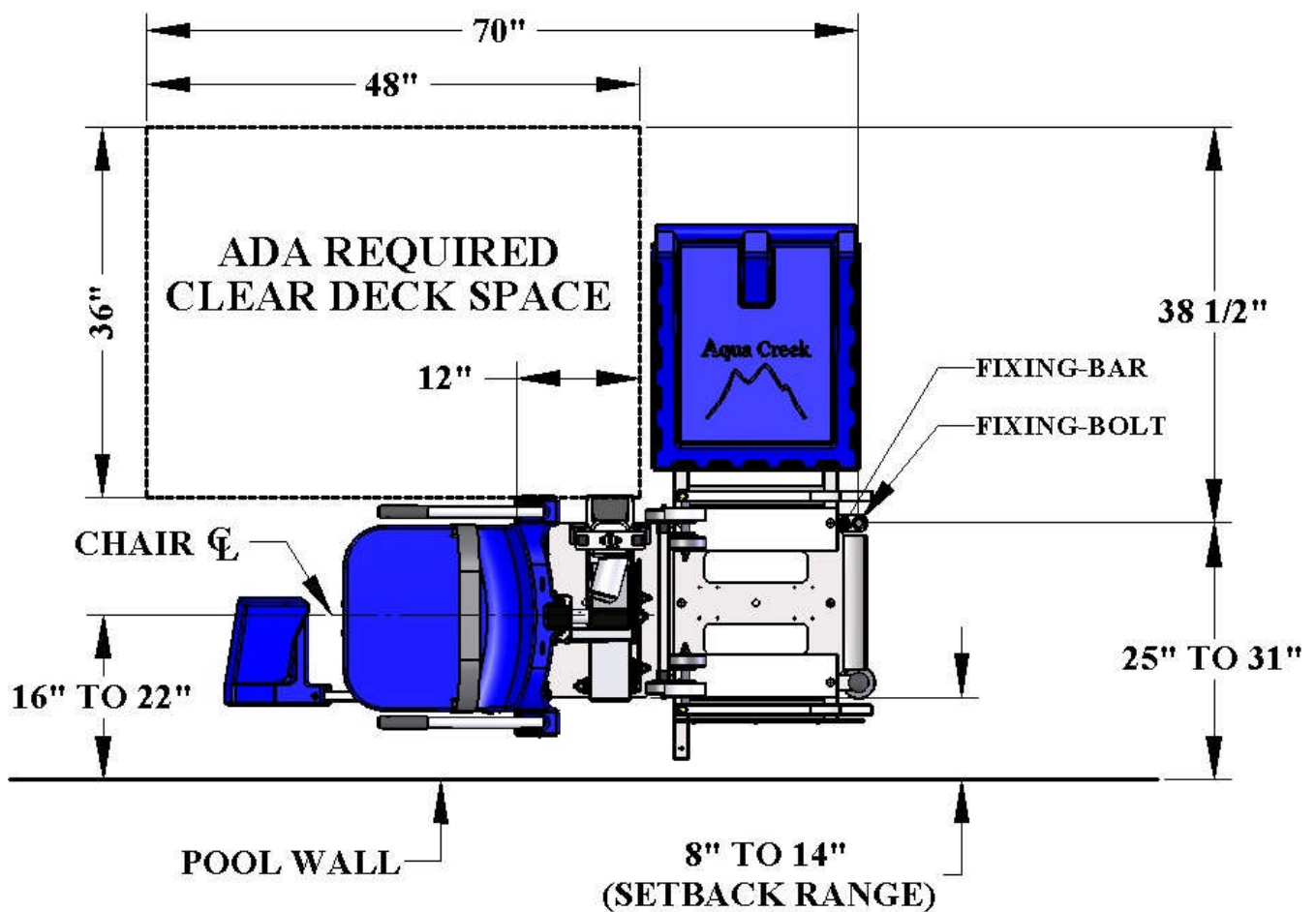

NOTE: The FIXING BOLT is used to fix the portable lift in place, and to ensure that it remains in an ADA approved location. This makes the lift fully ADA compliant to the latest revision.

THE PATRIOT-AT™ PORTABLE LIFT



WARNING

- 1. NEVER OPERATE THIS LIFT IF THE POOL DECK TO WATER LEVEL EXCEEDS 9"**
- 2. BEFORE OPERATING THE LIFT THE CONCRETE WEIGHTS MUST BE INSTALLED AS PER THESE INSTRUCTIONS. (SEE PAGE 5).**
- 3. IMMEDIATELY PUT THE BATTERY ON THE CHARGER AND CHARGE THE 24V BATTERY FOR 24 HOURS BEFORE INITIAL USE.**

PARTS LIST: (SEE FIGURE 2)

1. PORTABLE CART W/ WHEELS
2. INTEGRATED LIFT/ROLL-BASE
3. WEIGHT COVER W/ HANDLE
4. CONCRETE WEIGHTS (10)
5. 24V BATTERY
6. HANDSET CONTROL
7. BATTERY CHARGER

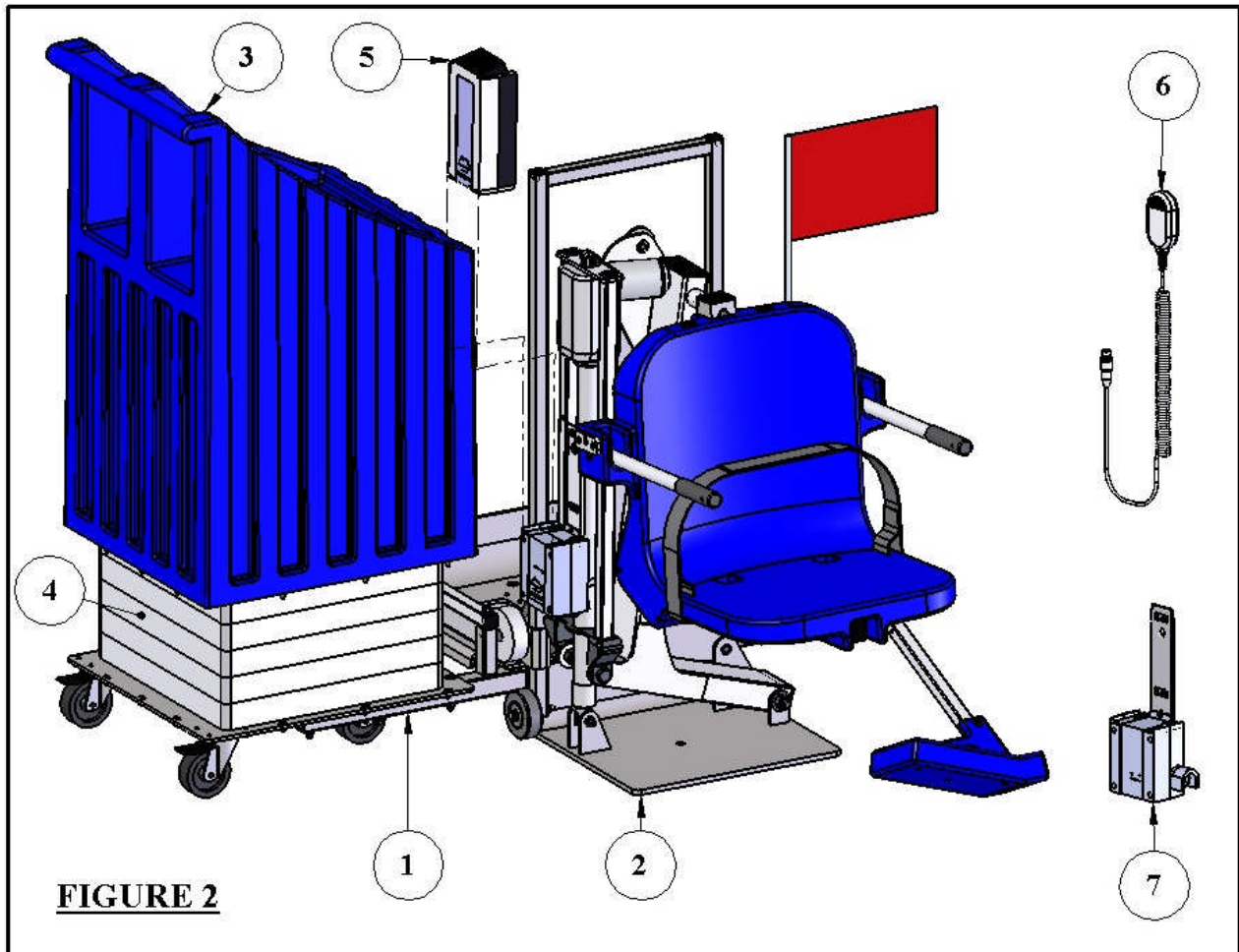

PATRIOT-AT2 ASSEMBLY INSTRUCTIONS

1. Begin by placing the parts from the previous page at or near to the desired poolside location.
2. **Stack 10 supplied weight plates on the portable platform.** To ensure proper alignment stack 3 to 4 plates, check alignment by temporarily putting the cover on, remove the cover and then stack 3 to 4 more plates. Repeat until all 10 weight plates are on the platform and properly aligned.
3. Attach the weight stack cover assembly over the weight stack using the supplied $\frac{1}{4}$ " NYLOCK NUTS and $\frac{1}{4}$ " FLAT WASHERS. **NOTE:** Be sure to use silicone to seal the flange before bolting together.

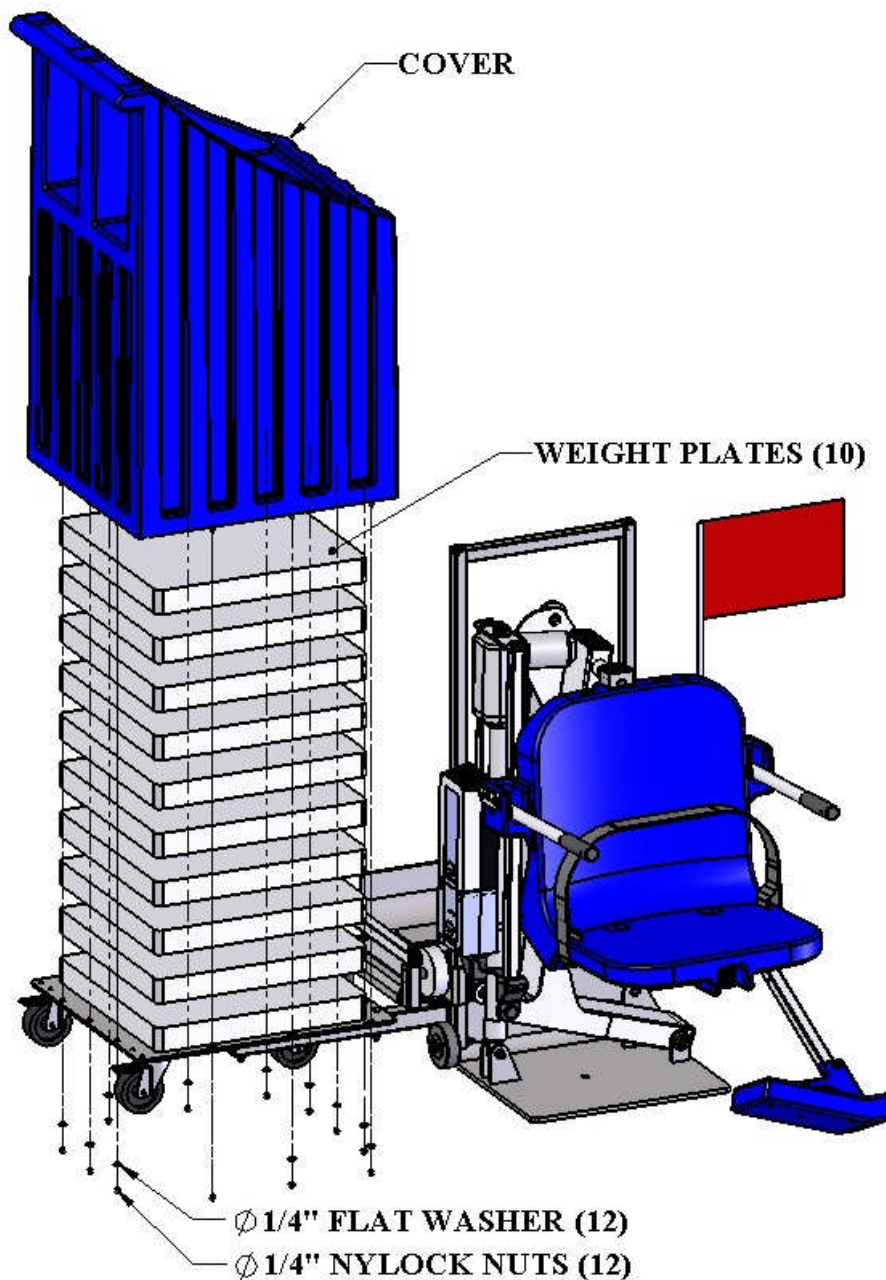

FIXING-ANCHOR INSTALLATION INSTRUCTIONS:

TOOLS REQUIRED:

CORE-DRILLING RIG
1-1/4" DIAMETER CORE-DRILL

TAPE MEASURE
MARKING PEN

STEP 1] Use the diagram below to determine the location of the FIXING ANCHOR. Make sure to allow for the clear deck space as shown.

STEP 2] Mark the location for the 1-1/4" x 4" deep anchor hole. Drill a 1-1/4" diameter, 4" deep hole at the marked location.

STEP 3] Dry-fit the anchor-insert to make sure it fits flush with the deck surface.

STEP 4] Fill the hole 1/2 full with epoxy. Install the anchor insert flush with the deck surface. Allow 24 hours for the epoxy to cure.

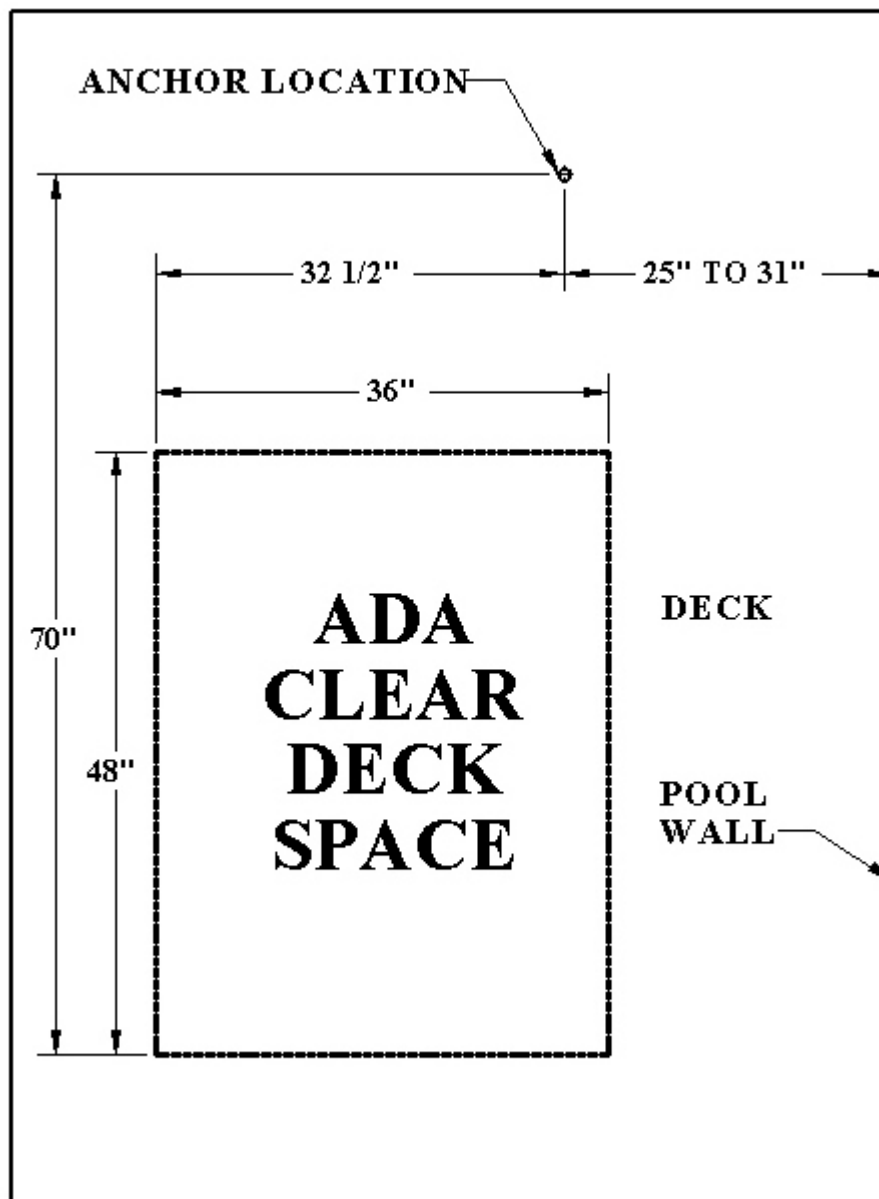

INSTALLING THE FIXING BOLT:

When the FIXING-BOLT is utilized to ensure proper placement of the portable lift the following procedure should be used when placing the unit in position on the deck.

STEP 1: Roll the portable cart over the installed anchor. Look straight down through the FIXING BAR to align the anchor with the FIXING BAR.

STEP 2: Drop the 1/2" x 4" FIXING BOLT into the FIXING BAR and start to thread the bolt into the anchor by hand. Adjust the alignment until the bolt threads in a couple of threads by hand. This is to ensure that the bolt is properly aligned before threading with a wrench.

STEP 3: Tighten the FIXING BOLT with a 3/4" wrench or socket. Tighten until the bolt is just touching the flat washer. **DO NOT OVERTIGHTEN.**

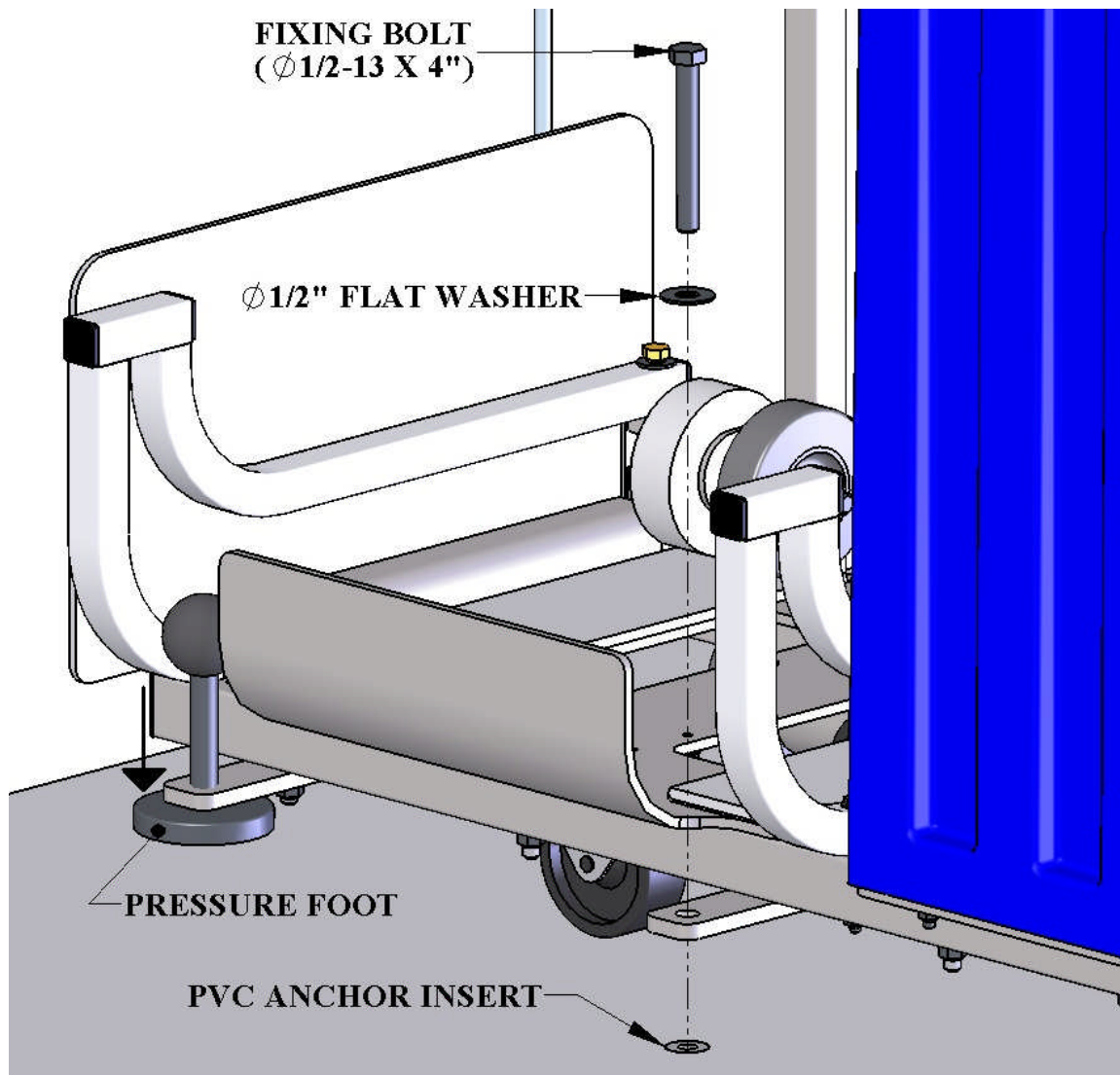

TRANSPORTING & USING THE PATRIOT-AT™ LIFT:

The Patriot-AT™ Lift has been designed to make transporting and using the lift as simple as possible. The design makes the lift 100% ADA compliant by providing two separate operating modes; one for transporting the lift and one for using it.

DO NOT ATTEMPT TO USE THE LIFT WHILE IN THE TRANSPORT MODE!

MODES OF OPERATION:

- 1) **TRANSPORT MODE:** In this mode the lift is on top of the portable cart and the brake-foot is raised, allowing the lift to roll and turn freely. The safety flag also inhibits use of the lift while in this position.
- 2) **OPERATION MODE:** In this mode the lift is on the deck surface and the brake-foot is lowered, keeping the cart and lift stable and stationary. To place the lift in this position, follow the instructions below.

TRANSPORT INSTRUCTIONS:

- 1) Roll Patriot-AT Lift to designated position on the deck. Install fixing-bolt (when required). Stand behind the lift and tilt it back and down as shown below. Tilt the lift to almost horizontal to make rolling and pivoting as simple as possible.
- 2) Roll the lift forward until it comes to the end and the pins engage with the slots.
- 3) Rotate the lift forward and down until it rests flat on the deck. Turn the handle of the brake-foot clockwise until the brake-foot is firmly in contact with the deck. The lift is now ready to use.

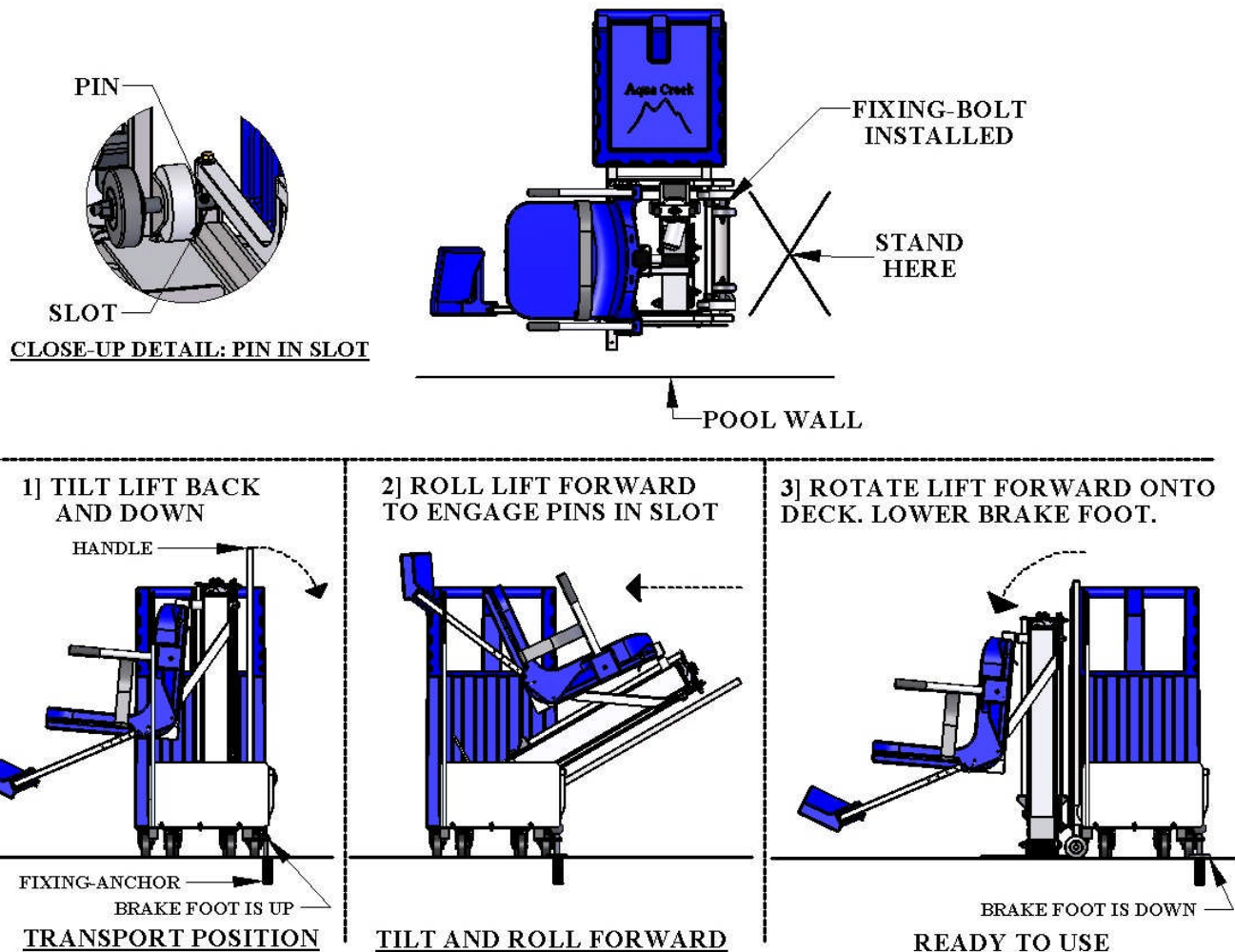

RETURNING THE LIFT TO TRANSPORT MODE:

To move the lift after use, reverse the steps above as follows:

- 1) Tilt the lift back and down until the lower wheels are at the cart level.
- 2) Roll the lift back and onto the cart. Roll all the way back to the end of the guide frames (see close-up detail).
- 3) Pivot the lift forward and down until it is resting on the cart. Rotate the brake-foot handle counter-clockwise and raise it off the deck. **REMOVE THE FIXING-BOLT** (if applicable). The lift is now ready to move.

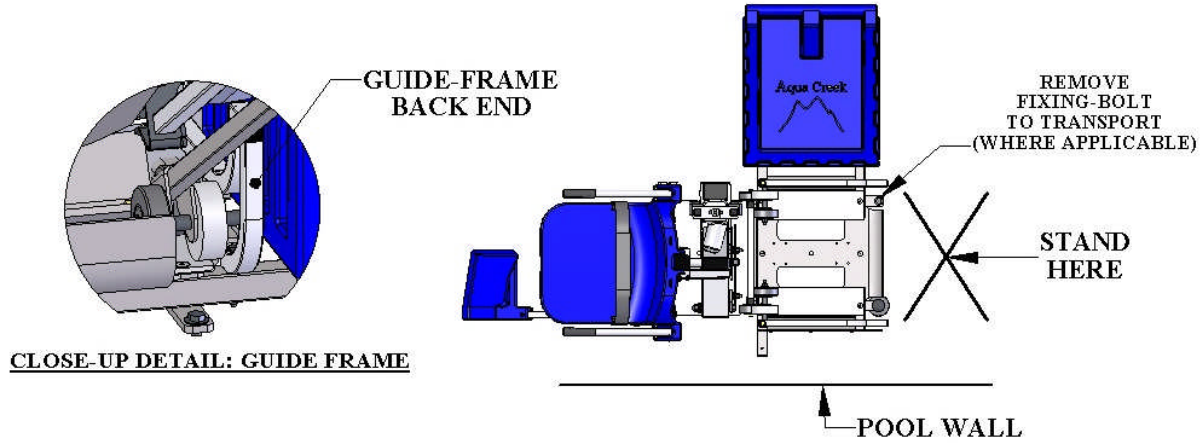

1] ROTATE LIFT BACK UNTIL LOW WHEELS ARE @ CART LEVEL.

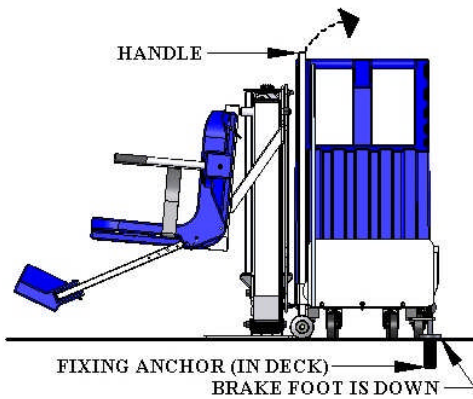

2] ROLL LIFT BACK TO END OF GUIDE FRAMES.

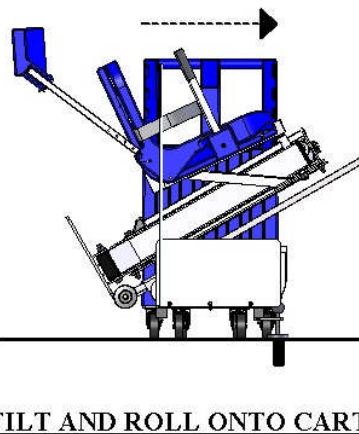

3] TILT LIFT FORWARD ONTO CART FOR TRANSPORT.

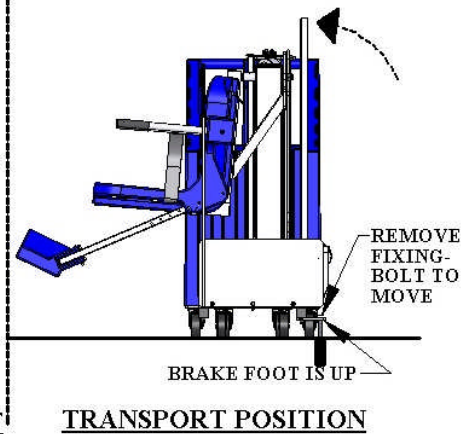

24V BATTERY SYSTEM OPERATING AND INSTALLATION INSTRUCTIONS



24V SEALED BATTERY



WALL MOUNT CHARGER



CONTROL BOX
& HANDSET REMOTE

The Patriot-AT™ Lift comes with a 24v sealed rechargeable battery, wall mount charging unit (with mounting bracket), control box, and a waterproof handheld controller. The control box is mounted to the Patriot-AT™ Lift and has a plug-in socket for both the actuator and the handheld controller. The battery mounts directly above the control box with a quick-release clip.

To operate the Patriot-AT™ Lift, plug in the handheld controller to the control box and push the corresponding button to either lower or raise the unit. The lift should be able to complete approximately 10-20 full cycles before the low battery indicator tone will sound. The low battery tone indicates that there is approximately 20% battery life remaining. At this point, **DO NOT ATTEMPT TO OPERATE THE LIFT**, remove the battery from the unit and recharge on the wall mounted charging unit.

To recharge the battery, simply grip the top of the battery and depress the clip on the back of the battery. This will unclip the battery from the control box bracket and the battery can then be clipped into the wall mount charger. When the **charger** is plugged in the green **ON** light will illuminate. When the **battery** is correctly mounted to the charger, the orange **CHARGE** light will illuminate. When the battery is fully charged, the **CHARGE** light will **GO OFF** and the battery is ready to use. The battery charger will automatically shut off when the battery is fully charged, so the battery can stay on the charger any time it is not being used.

DO NOT LEAVE THE BATTERY ON THE LIFT. WHEN NOT IN USE STORE THE BATTERY ON THE CHARGER.

BATTERY MAINTENANCE

1. **RECHARGE THE BATTERY AS OFTEN AS POSSIBLE.** The battery power unit is a sealed lead acid battery pack. Frequent recharges will prolong the battery life and maintain a high cold amperage capacity.
2. Do NOT expose the battery to freezing temperatures.
3. Do NOT expose the battery to prolonged periods of extreme heat or severe cold temperatures.
4. Do NOT expose the battery to long periods of direct sunlight. Heat will shorten your battery life. Optimum operating temperature is below 20 degrees Celsius (68 degrees F.)
5. Never drop or bump the battery pack. This may result in loose or damaged internal connections, and may bend the battery terminals.
6. Keep battery terminals clean and free from dirt and corrosion to ensure good contact. The terminals may be cleaned using Scotch Brite or any similar product. Clean off any corrosion or discoloration on the very top surfaces of the battery contacts and then apply dielectric grease (supplied with lift) as shown in the figure below.

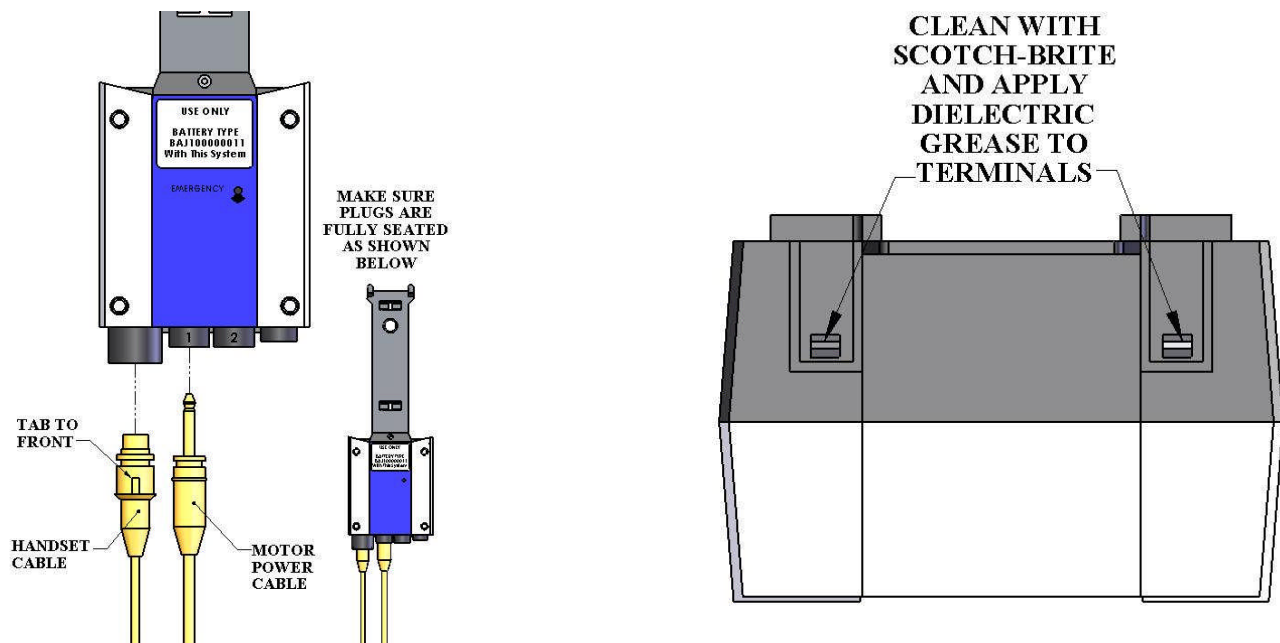

USING THE “EMERGENCY BUTTON” on the Pro Pool Lift Control Box

On the front side of the control box is a small recessed button marked “emergency”. Take a pen or pencil or other pointed object and depress the “emergency” button. This will bypass the remote control and send a signal directly to the actuator to raise the seat out of the pool and back to the deck or up position.

NOTE: This function will only work if there is sufficient power in the battery, the battery is properly attached to the control box, and the control box must be operating properly.



PRO POOL LIFT OPERATING INSTRUCTIONS:

NOTE: CHECK ALL NUTS & BOLTS FOR TIGHTNESS AND FOR WORN PARTS BEFORE EACH USE. NEVER OPERATE THE LIFT WITH THE ARMRESTS FLIPPED UP.

WARNING! FOR SAFETY REASONS YOU SHOULD NEVER SWIM ALONE!

The Pro Pool Lift™ should always be in the full up or deck position before a user attempts to transfer into the chair. Before attempting to transfer into the chair, check to make sure the lift is operating by making a short test run: move the chair at least part way in and out of the pool.

As you are standing in front of the chair, facing the chair, the armrest on either side will flip up to allow for easier lateral transfers. Transfer into the chair and then lower the flip-up armrest back into its normal position. Secure the adjustable lap belt around the waist so that the belt is snug, but not uncomfortably tight.

You are now seated comfortably in the Pro Pool Lift™, and ready to move into the pool or spa. Before you begin the operating cycle, take a visual check of the deck area and pool area to make sure the operating path of the lift is clear.

It is not necessary to lower the lift all the way to the bottom of the lift's stroke. You may stop the lift at any time in the downward cycle when it is comfortable for you to exit the chair into the water.

This is NOT true however, when returning to the deck during the up cycle. The lift should always be cycled completely to the up or deck position before attempting to exit the chair on the deck.

To lower the lift into the pool, simply apply pressure on the down arrow button on the remote control handset and the chair will start to move towards the pool. NOTE: for safety reasons, it is necessary to maintain continuous pressure on the control button. If you take your finger off of the control button the lift will stop.

When you are sufficiently submerged into the water to allow for an easy exit from the chair, you may stop the lift cycle by releasing pressure on the down arrow button on the remote control handset. Now release the lap belt by grasping the end of the belt that is protruding above the lap belt and tugging gently. You may now flip up the footrest to create more room in front of the chair for you to exit. Exit the chair by sliding straight forward until you are clear of the seat and the footrest.

When you are ready to return to the lift seat and exit the pool or spa, make sure that the chair is lowered (submerged) sufficiently to allow you to easily slide into the chair. You should not attempt to "lift" or raise yourself into the chair. Once you are resealed into the chair, you may lower the footrest to its normal operating position and place your feet on the footrest. Next, re-secure the adjustable lap belt snugly around your waist. To raise the chair out of the pool, simply press on the up arrow button on the remote control handset and apply continuous pressure until the lift chair comes to a rest on the deck in the full up position. You may now release the lap belt and exit the chair.

SAFETY & MAINTENANCE INSTRUCTIONS

Do not play on or around this lift

1. Check the PATRIOT-AT™ LIFT before each use to assure there are no worn parts and that all hardware is properly tightened. If there are any worn parts, replace them BEFORE using the PATRIOT-AT™ LIFT. You can call our customer service at 1-888-687-3552 to order any parts.
2. Aqua Creek Products, LLC lifts shall be grounded per local codes.
3. At least ONCE A WEEK, the PATRIOT-AT™ LIFT must be cleaned with fresh water. Do not spray the PATRIOT-AT™ lifts' control box or battery directly with any pressure. Wipe all surfaces clean with a damp, non-abrasive cloth. When cleaning the PATRIOT-AT™ LIFT, use non-abrasive soap and water. Avoid harsh chemicals and disinfectants.
4. Always read the label instructions on any cleaner carefully before applying it to a surface.
5. The WARNING & INTENDED USE labels on the PATRIOT-AT™ LIFT need to be maintained in readable fashion. If they become unreadable or faded, please replace the label immediately. Replacement labels are available from AQUA CREEK PRODUCTS LLC. 1-888-687-3552.

Aqua Creek Pool Lift should not be stored in a pump room or in a storage room where pool chemicals are kept. Storing the lift near pool chemicals may cause rusting and other damage to occur. Your Aqua Creek stainless steel lift is powder coated to protect the stainless steel from rusting. Most rusting will occur at weld points, crevices, under gaskets, rivets or bolt heads.

The choice of a proper cleaning product is up to the consumer and there are many to choose from. Depending on the type of cleaning and the degree of contamination (rusting), some products are better than others. For routine cleaning the products most recommended are gentle soaps or detergents or dilute mixtures of ammonia. For stubborn spots and stains try using soft scrub with some brisk rubbing.

DO NOT USE POOL WATER TO CLEAN USE ONLY FRESH WATER

If the lift is used **DAILY** make sure to wash the lift at the end of the day. Wash the lift off using a mild soap and a soft cloth. Make sure to pay special attention to weld points and crevices. Do not use a bristled brush or steel wool to clean the lift. Check that the lift is working properly and then place the battery on the charger. It is recommended that the battery be charged after every day of use.

If the lift is used **WEEKLY** follow the same steps as above. Also be sure to check all of the contact points (terminals) for damage or corrosion. If you notice corrosion gently clean the terminals. To clean corrosion from the terminals use a q-tip and some rubbing alcohol. If the corrosion is particularly stubborn try using a 3M scotch brite pad, but be careful not to damage the terminals. Apply dielectric grease to the terminals after cleaning them. This will help to prevent further corrosion. Do not leave the battery on the lift. Always store the battery on the charger whenever the lift is not being used.

If the lift is used **MONTHLY** follow the same steps as above. Also check the nuts and bolts to make sure they are securely fastened (this is always a good idea, no matter how often or infrequently the lift is used). Also make sure to store the battery on the charger and not on the lift. Leaving the battery on the lift for extended periods will significantly shorten the battery's lifespan.

If the lift is being **STORED** for an extended period of time follow all of the steps above. Check for rusting at all crevice and weld points. If you notice rusting spray some WD-40 on the affected area and take a 3M scotch brite pad and rub briskly. Afterwards be sure to wash and rinse the lift again with soap and water. When storing the lift make sure it is in a dry area and covered. **DO NOT STORE** in or around pool chemicals.

TROUBLESHOOTING GUIDE

Before troubleshooting make sure the battery is fully charged.

If the lift doesn't move when the handset button is pressed:

When you can't get the lift to move check the following things:

1. Make sure the battery is fully charged:
 - A. Before charging the battery first make sure the **green** light on the front of the charger is illuminated (this means that the charger is on). Then check to make sure the silver contact points on the battery and charger are not damaged or corroded, and that they are clean. Then place the battery on the charger and look for the **orange** charge light to illuminate on the front of the charger. When the orange light goes off the battery is fully charged.

The top **green light** will always be illuminated indicating that it has power. When charging the battery the bottom **orange light** will illuminate, until fully charged.



- B. When the battery is correctly installed on the charger or control box you should hear a “click” indicating the battery is properly seated on the unit. Also note that when the battery is properly seated there should not be any gaps between the battery and the control box/charger.



Not attached properly. Note the white bracket is in front of silver clip, which will not allow for an electrical connection.



Properly Attached. Note that the white bracket is behind the silver clip. Not allowing movement.

If the battery is fully charged and the lift is not moving then:

2. Check all cords:

- A. Check that the cords are properly plugged in. Start by unplugging the remote and the actuator cord from the control box. Once these cords are removed check the ends for corrosion or damage. Plug the remote cord back in by lining up the raised tab on the plug to the grooved line on the control box outlet. Note that these cords require some force to plug them in fully. You will know they are correctly inserted when you hear a “popping sound”. The cords will be recessed into the outlet. If they are flush with the outside of the outlet they are not plugged in fully and the lift will not function. Make sure you do this for both cords.



NOT inserted fully.



Fully inserted.

If you have checked all the cords and the lift still doesn't move:

3. Check the contact points:

- A. After you have fully charged the battery and checked the cords to make sure they are properly plugged in, check to make sure the contact points are not corroded or bent. If the contact points are corroded take some rubbing alcohol and a q-tip and clean off the points. After cleaning the contact points it is recommended to put some dielectric grease on the contact points (terminals) to help ensure good electrical contact and prevent corrosion. Then reinstall the battery on top of the control box. Make sure you hear a “click”, which indicates that the battery is correctly seated. The lift will not work if the battery is not seated correctly.

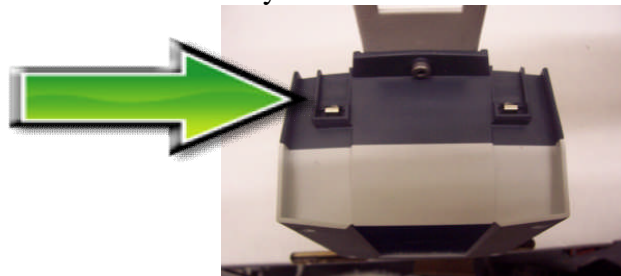

Silver tabs are the contact (terminal) points.

If the lift stops moving over the water and is stuck:

4. Then try pushing the emergency button:

A. If the lift gets stuck out over the water use a pen or pencil tip and stick it into the emergency button on the front of the control box to retract the lift. Note the lift will not retract if the battery is not fully charged or if the control box is not working. The emergency button only overrides the remote in case it has gone bad. If this does not retract the lift then chances are the remote is fine and you either have a problem with the battery, the control box, or the cords are damaged or not plugged in properly.

Use a pen or pencil tip to push in the small black circle located next to the word **emergency**, on the front of the control box.



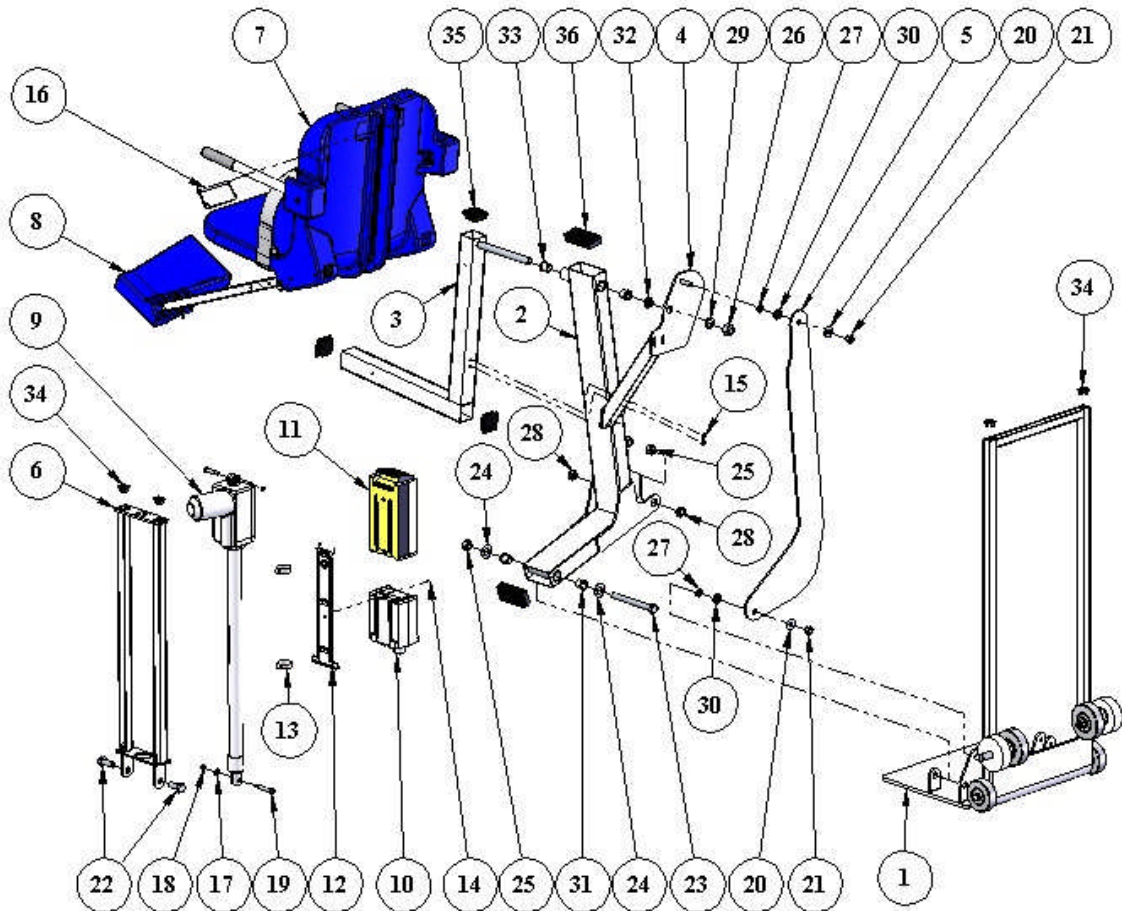

PATRIOT-AT2™ INTEGRATED LIFT: PARTS LIST

ITEM NO.	QTY.	PART NUMBER	DESCRIPTION
1	1	RAT-200-20	REBEL-AT ROLL-BASE ASSY
2	1	PPF-200-10	RANGER-AT FRAME ASSY
3	1	A-2012ARM-R1	PORTABLE CHAIR ARM ASSY
4	1	A-2012SRS-R1	PRO POOL SEAT SUPPORT
5	1	L-2014FBL-PAT-R2	RANGER-AT CONTROL ARM
6	1	A-8980PPAF-AT2	PRO POOL-AT ACTUATOR FRAME
7	1	SA-0904CA-A	18" CHAIR ASSEMBLY
8	1	SA-0904FRA	FOOTREST ASSEMBLY
9	1	340461-00	600mm ACTUATOR, PATRIOT
10	1	CBJ2001NA001381	CONTROL BOX, PRO POOL & PATRIOT
11	1	BAJ100000291	24V BATTERY W/ACP LOGO
12	1	MBJ2-01	MOUNTING BRACKET (control box & battery)
13	2	HOSE CLAMP, 1-3/4" SS	HOSE CLAMP, 1-3/4" SS
14	1	M5 X 10 LPCS, SS	M5 X 10mm LOW-PROFILE CAP SCREW, SS
15	2	BOLT, 1/4 X 3/8 HWH	1/4" X 3/8" HEX WASHER HEAD, SS
16	1	SNAP PIN 5/16 x 4 1/2" SS	SNAP PIN 5/16" x 4 1/2" USABLE LENGTH SS
17	1	FLAT WASHER, 5/16 SS	5/16" FLAT WASHER, 316 SS
18	1	NYLOCK, 5/16 SS	5/16"-18 NYLOCK NUT, SS
19	1	BOLT, 3/8 X 1 3/4 SHOULDER	3/8" X 1-3/4" SHOULDER BOLT, SS
20	2	FLAT WASHER, 1/2 SS	1/2" FLAT WASHER, 316 SS
21	2	NYLOCK, 1/2 SS	1/2"-13 NYLOCK NUT, 316 SS
22	2	BOLT, 5/8 X 1 1/2 HCS	5/8"-11 X 1-1/2" HEX BOLT, SS
23	1	BOLT, 5/8 X 6 HCS	5/8"-11 X 6" HEX BOLT, CUSTOM, SS
24	2	FLAT WASHER, 5/8 SS	5/8" FLAT WASHER, 316 SS
25	3	NYLOCK, 5/8 SS	5/8"-11 NYLOCK NUT, 316 SS
26	1	NYLOCK, 3/4 SS	3/4"-10 NYLOCK NUT, 316 SS
27	2	TT-1001-1	7/8" OD X 1/2" ID X 1/8" TH-WSR, BRNZ
28	2	MACH-BUSHING, 7/8 X 5/8 X 1/4	5/8" X 7/8" X 1/4" CUSTOM BUSHING
29	1	TT-1205-1	1-1/4 X 3/4 X 1/8 TH-WSR, BRONZE
30	2	FL-50-3	1/2" X 5/8" X 3/8" FLANGE BEARING, BZ
31	2	FL-64-6	7/8 X 5/8 X 3/4 FLANGE BEARING, BZ
32	1	MACH-BUSHING, 7/8 X 3/4 X 1/4	3/4 X 7/8 X 1/4 CUSTOM BUSHING
33	2	FL-75-6	3/4 X 7/8 X 3/4 FLANGE BUSHING, BZ
34	6	SQR-1-14-20	1" X 1" SQUARE BLACK CAP
35	3	SQR-2-10-14	2" X 2" SQUARE BLACK CAP
36	2	RER-50X100mm	2" X 4" RECT. BLACK CAP

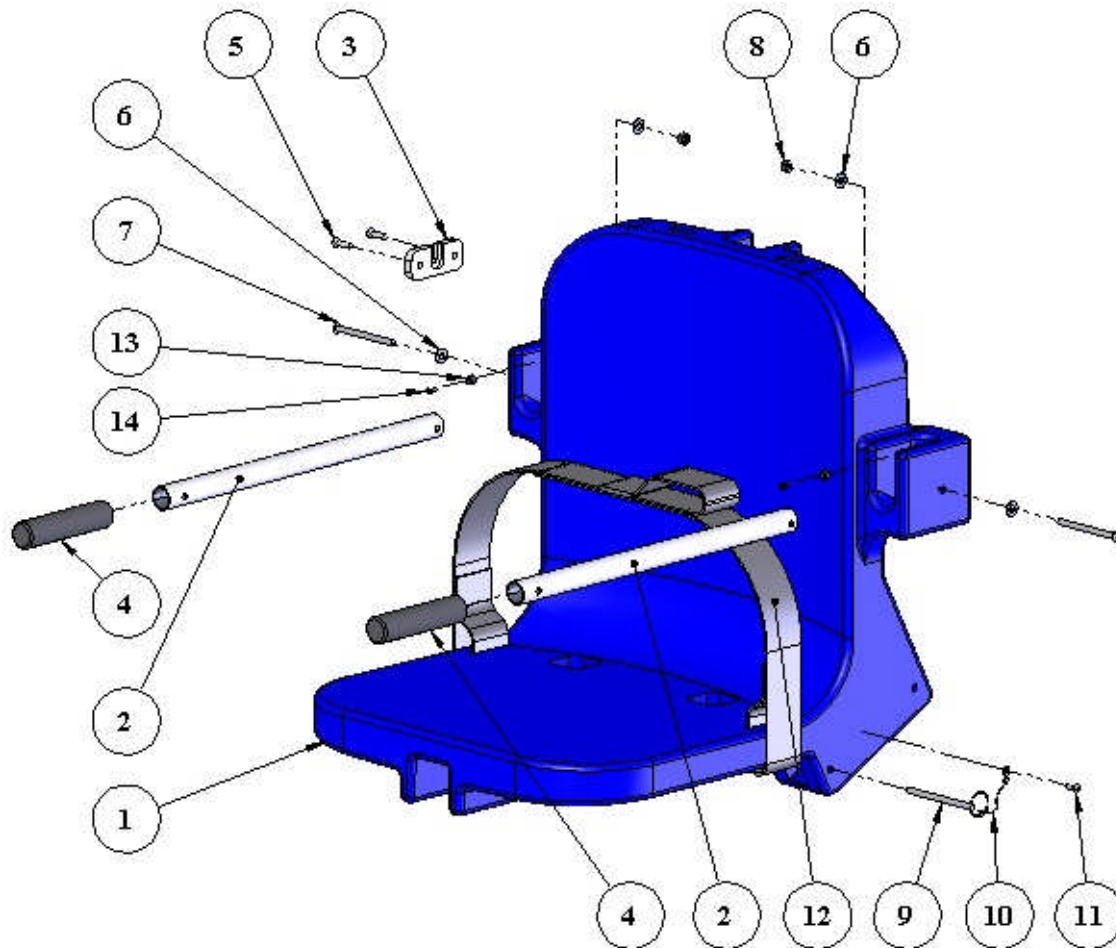

SEAT ASSEMBLY: PARTS LIST

ITEM NO.	QTY.	PART NUMBER	DESCRIPTION
1	1	P-901	CHAIR, BLUE ROTOMOLDED (18" WIDE)
2	2	P-2100FLA-A	ARMREST TUBE
3	1	P-1208HSB	HANDSET BRACKET, HDPE
4	2	RUBBER HAND GRIPS	RUBBER HAND GRIPS, BLACK
5	2	SCREW, #12 X 3/4 FHSMS	#12 X 3/4" FLAT-HD SHEET-METAL SCR SS
6	4	FLAT WASHER, 1/4 SS	1/4" FLAT WASHER, 316 SS
7	2	BOLT, 1/4 X 3 1/4 BHSCS	1/4"-20 X 3-1/4" BUTTON-HD CS, SS
8	2	NYLOCK, 1/4 SS	1/4"-20 NYLOCK NUT, SS
9	1	COTTER PIN, 1/4 X 3 1/4	1/4" X 3-1/4" QUICK-PULL PIN FOR FOOTREST
10	1	LANYARD	SS LANYARD FOR FOOTREST PIN
11	1	SCREW, #10 X 3/4 PHSMS	#10 X 3/4" PAN-HEAD SHEET-METAL SCR, SS
12	1	F-38SB	SEAT BELT, 2" BLACK W/VELCRO FOR PP
13	2	RUBBER BUMPER 3/8	3/8" RUBBER BUMPER, BLACK
14	2	SCREW, #6 X 1/2 PHSMS	#6 X 1/2" PAN-HD SHEET-METAL SCR, SS

PATRIOT-AT2™ PORTABLE CART: PARTS LIST

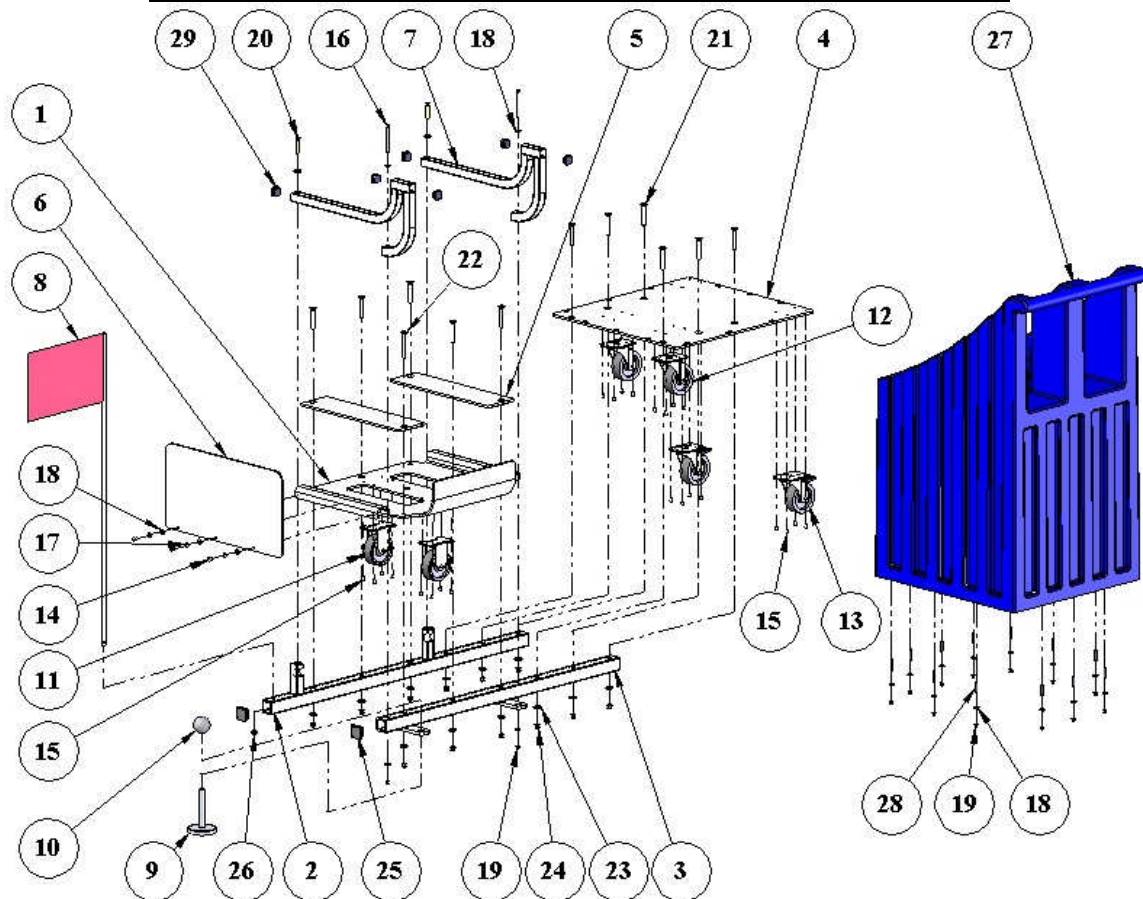

ITEM NO.	QTY.	PART NUMBER	DESCRIPTION
1	1	RAT-110-00	AT CART TRAY
2	1	RATWM-120-00	AT CART WELDMENT A
3	1	RATWM-130-00	AT CART WELDMENT B, 2-ANC
4	1	P-0138PBP-REVA2	PORTABLE CART BASEPLATE
5	2	P-0138PCPS-REVB	PORATBLE CART PLASTIC SLIDE
6	1	P-0138PCPG-REVB	PORTABLE CART SIDE GUARD, PLASTIC
7	2	A-0138GFA-REVC	GUIDE-FRAME ASSEMBLY, REVISION C
8	1	SAFETY FLAG	SAFETY FLAG, RED
9	1	1942K76	PATRIOT BRAKE FOOT
10	1	65137374	PRESSURE FOOT/BRAKE HANDLE
11	2	2.03408.471	CASTER, SS, FIXED 3-1/2"
12	2	2.03456.471	CASTER, SS, SWIVEL 3-1/2"
13	2	2.03456.471BRK2	CASTER, SS, SWIVEL W/BRAKE 3-1/2"
14	3	BOLT, 1/4 X 1/2 BHSCS	1/4"-20 X 1/2" BUTTON-HD CS, 316 SS
15	24	BOLT, 1/4 X 3/8 HWH	1/4" X 3/8" HEX WASHER HEAD, SS
16	2	BOLT, 1/4 X 3 HCS	1/4"-20 X 3" HEX BOLT, 316 SS
17	3	LOCK WASHER, 1/4 SS	1/4" LOCK WASHER, 316 SS
18	19	FLAT WASHER, 1/4 SS	1/4" FLAT WASHER, 316 SS
19	14	NYLOCK, 1/4 SS	1/4"-20 NYLOCK NUT, 316 SS
20	2	BOLT, 3/8 X 1 1/2 HCS	3/8"-16 X 1-1/2" HEX BOLT, 316 SS
21	10	BOLT, COUNTERSINK 3/8 x 2 1/2	3/8"-16 X 2-1/2" FLAT-HD CS, 316 SS
22	2	BOLT, COUNTERSINK 3/8 x 3	3/8"-16 X 3" FLAT-HD CAP-SCR, 316 SS
23	14	FLAT WASHER, 3/8 SS	3/8" FLAT WASHER, 316 SS
24	12	NYLOCK, 3/8-16 JAM	3/8"-16 HEX-JAM NYLOCK NUT, 316 SS
25	2	SQR-1-1/2-10-14	1-1/2" SQ. PLASTIC CAP, BLACK
26	1	NUT, 3/8-24, JAM NUT, SS, HEX	3/8"-24 JAM-NUT, HEX SS
27	1	P-985	PATRIOT-AT2 WEIGHT COVER/HANDLE
28	12	SET SCREW, 1/4 X 1 1/4 SS	SET SCREW, 1/4" X 1-1/4" 316-SS
29	6	SQR-1-14-20	1" X 1" SQUARE BLACK CAP

Aqua Creek Products, LLC Limited Warranty

Patriot-AT™ Portable Lift

Aqua Creek Products lifts have a **Limited Lifetime Warranty** on the frames, not including the powder coat finish. Aqua Creek Products, LLC (a.k.a. Aqua Creek) also warrants to the original end user that all non-frame components manufactured by Aqua Creek, when properly installed in accordance with assembly and installation instructions, and properly used and maintained, shall be free from defects in material and workmanship for a period of five (5) years from the date of original purchase, provided that Aqua Creek receives prompt notice in writing of any defect or failure and satisfactory proof thereof, with the following exceptions:

This warranty specifically excludes reimbursement for labor to remove, repair, or install the product and any return freight charges

These warranties do not cover any damages due to accident, misuse, abuse, negligence or failure to properly maintain any products, or normal wear and tear from day to day operations. In the event that any products are altered, repaired, or improperly installed or improperly used by anyone without the prior written approval by Aqua Creek, all warranties are void. **IMPORTANT: AMOUNT OF WEIGHT PLACED ON LIFT SHALL NOT EXCEED THE RATED LIFTING CAPACITY OF 450 POUNDS [204 kg] FOR THE PATRIOT-AT PORTABLE LIFT. NEVER OPERATE THE LIFT UNDER LOAD IN A DRY POOL (WITH NO WATER IN THE POOL).**

To initiate a warranty claim, the owner of an Aqua Creek product must provide the place of purchase, in writing, with a full description of the product, its serial number, the dates of purchase and installation, and the exact nature of the defect. Within thirty (30) days after receipt of a written warranty claim by Aqua Creek, and barring any unforeseen delays, the place of purchase will be notified of Aqua Creek's decision regarding the claim.

If requested by Aqua Creek, any defective product must be returned, freight prepaid, to Aqua Creek's designated factory location or duly appointed distributor for inspection and/or repair. Aqua Creek will, at its option, repair or replace the failed or defective item, and deliver the repaired product or replacement to the buyer of the product, freight prepaid to the destination provided for in the original order. Products returned to Aqua Creek for which Aqua Creek provides replacement under this limited warranty shall become the property of Aqua Creek.

A new warranty period shall NOT be established for the repaired or replaced products. Such products shall remain under warranty only for the remainder of the original warranty period on the original products purchased.

This written limited warranty constitutes the final, complete and exclusive statement of warranty terms. No person or organization is authorized to make any other specific or implied warranties or representations on behalf of Aqua Creek.

THE WARRANTIES SET FORTH HEREIN ARE IN LIEU OF ALL OTHER WARRANTIES, EXPRESSED OR IMPLIED, WHICH ARE HEREBY DISCLAIMED AND EXCLUDED, INCLUDING WITHOUT LIMITATION ANY WARRANTY OF MERCHANTABILITY OR FITNESS FOR A PARTICULAR PURPOSE OR USE.

THE SOLE AND EXCLUSIVE REMEDIES FOR BREACH OF ANY AND ALL WARRANTIES WITH RESPECT TO THE PRODUCTS SHALL BE LIMITED TO REPAIR OR REPLACEMENT AT AQUA CREEK'S DESIGNATED FACTORY LOCATION, OR DULY APPOINTED DISTRIBUTOR, OR IN PLACE AT AQUA CREEK'S OPTION. IN NO EVENT SHALL AQUA CREEK'S LIABILITY EXCEED THE ENTIRE AMOUNT PAID TO AQUA CREEK BY THE ORIGINAL PURCHASER FOR THE FAILED OR DEFECTIVE PRODUCT.

IN NO EVENT SHALL AQUA CREEK PRODUCTS, LLC BE LIABLE FOR ANY INCIDENTAL, CONSEQUENTIAL, SPECIAL, INDIRECT, PUNITIVE OR EXEMPLARY DAMAGES OR LOST PROFITS FROM ANY BREACH OF THIS LIMITED WARRANTY OR OTHERWISE.

THIS WARRANTY GIVES YOU SPECIFIC LEGAL RIGHTS, AND YOU MAY ALSO HAVE OTHER RIGHTS, WHICH MAY VARY FROM STATE TO STATE.

SOME STATES DO NOT ALLOW THE EXCLUSION OR LIMITATION OF INCIDENTAL, SPECIAL OR CONSEQUENTIAL DAMAGES, SO SOME OF THE ABOVE LIMITATIONS OR EXCLUSIONS MAY NOT APPLY TO YOU.

Aqua Creek Products
9889 Garrymore Lane
Missoula, MT 59808